

SEAT Sport

by TH0tronic

TITLE: MK3_TCR_LEON_schematic_details

Document Number: STARTER

REV:

Date: 25/02/2016 12:04:19

Sheet: 1/26

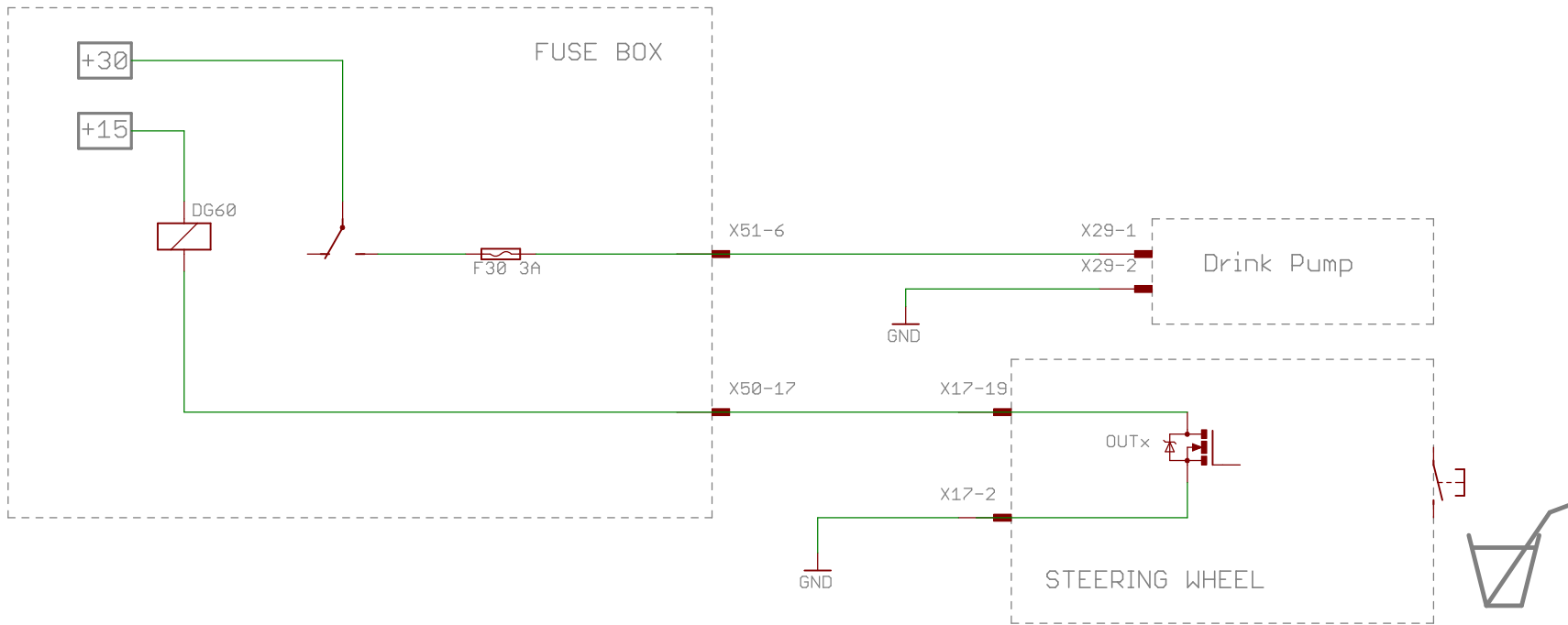

SEAT Sport

by THQtronic

TITLE: MK3_TCR_LEON_schematic_details

Document Number: DRINK

REV:

Date: 25/02/2016 12:04:19

Sheet: 2/26

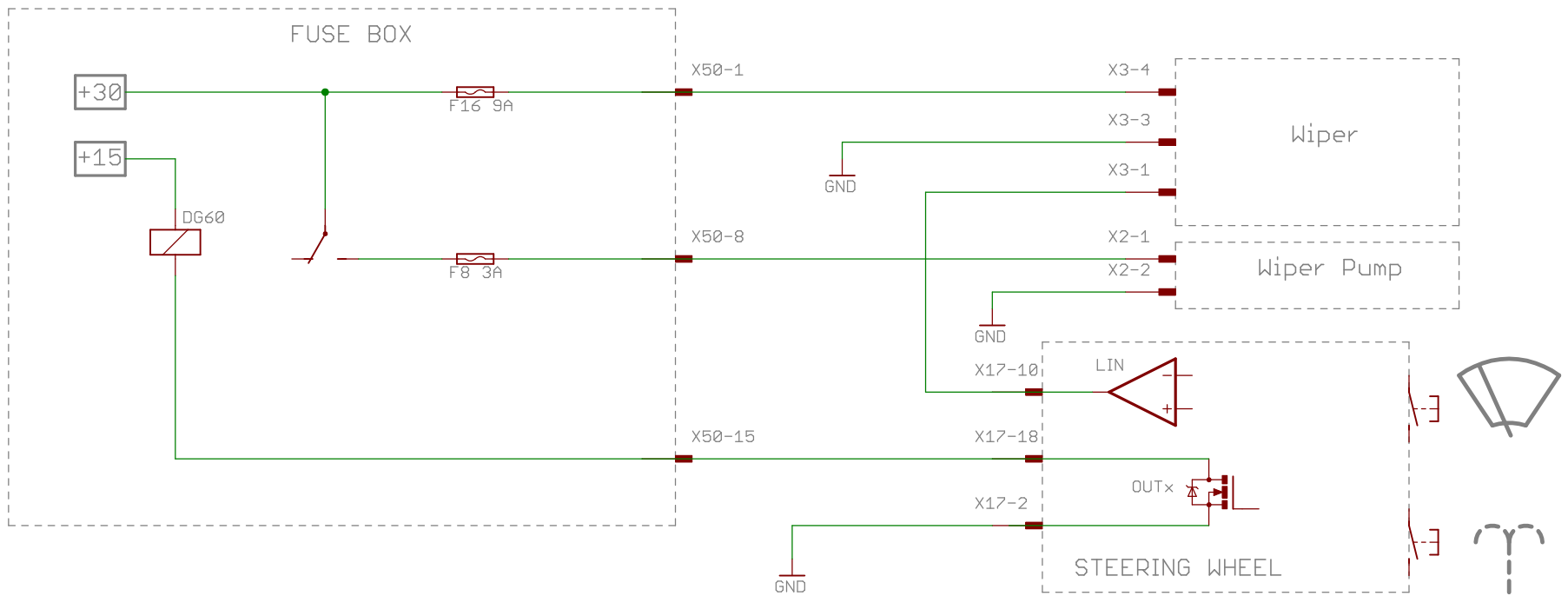

SEAT Sport

by THQtronic

TITLE: MK3_TCR_LEON_schematic_details

Document Number: WIPER REV:

Date: 25/02/2016 12:04:19

Sheet: 3/26

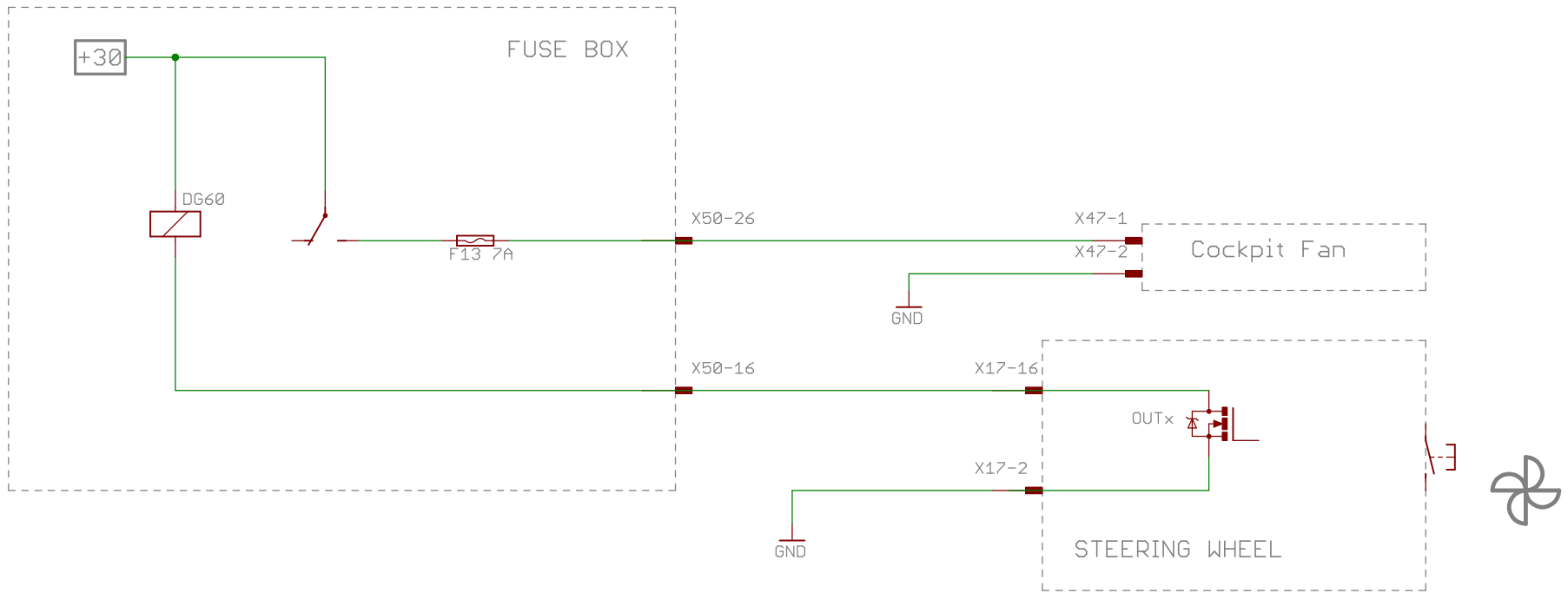

SEAT Sport

by THQtronic

TITLE: MK3_TCR_LEON_schematic_details

Document Number: Cockpit FAN

REV:

Date: 25/02/2016 12:04:19

Sheet: 4/26

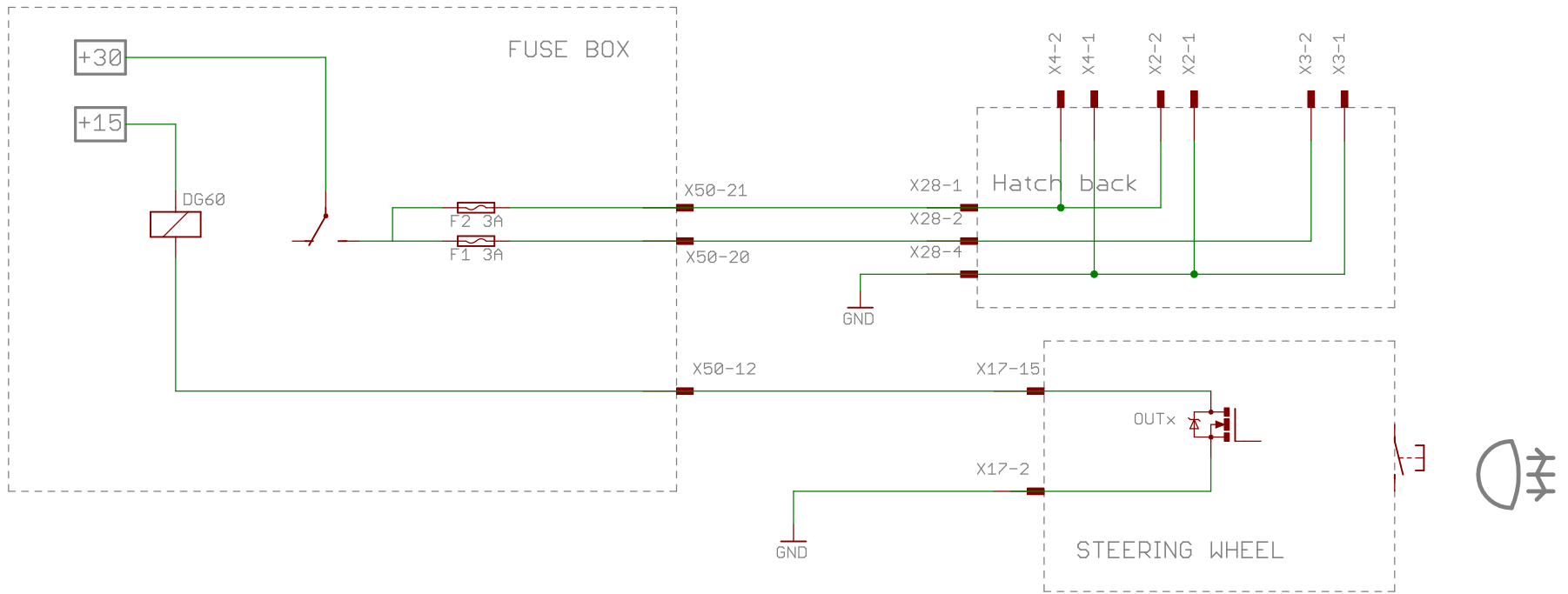

SEAT Sport

by THQtronic

TITLE: MK3_TCR_LEON_schematic_details

Document Number: Rain Light GOLF

REV:

Date: 25/02/2016 12:04:19

Sheet: 5/26

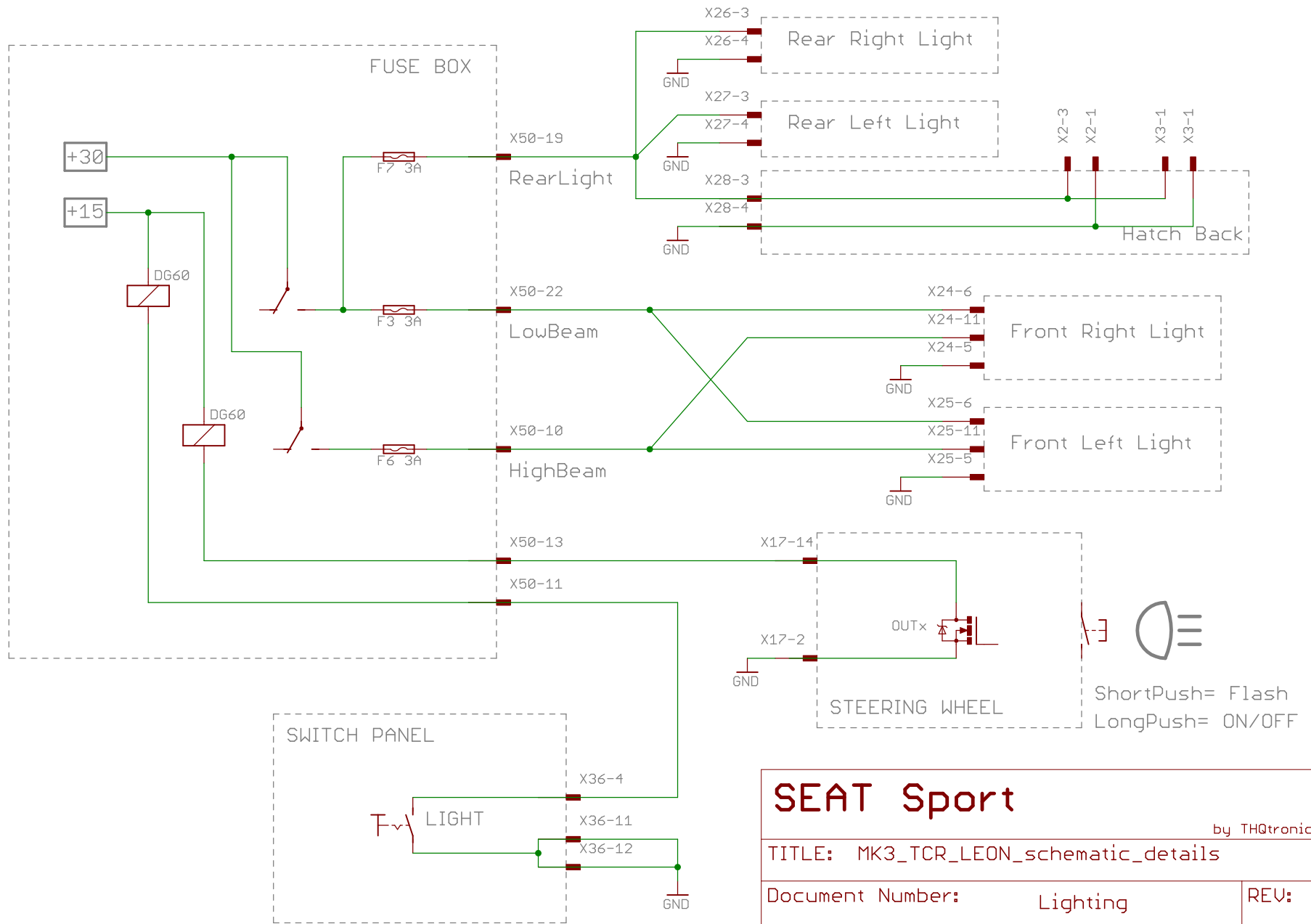

SEAT Sport

by THQtronic

TITLE: MK3_TCR_LEON_schematic_details

Document Number: Lighting

REV:

Date: 25/02/2016 12:04:19

Sheet: 6/26

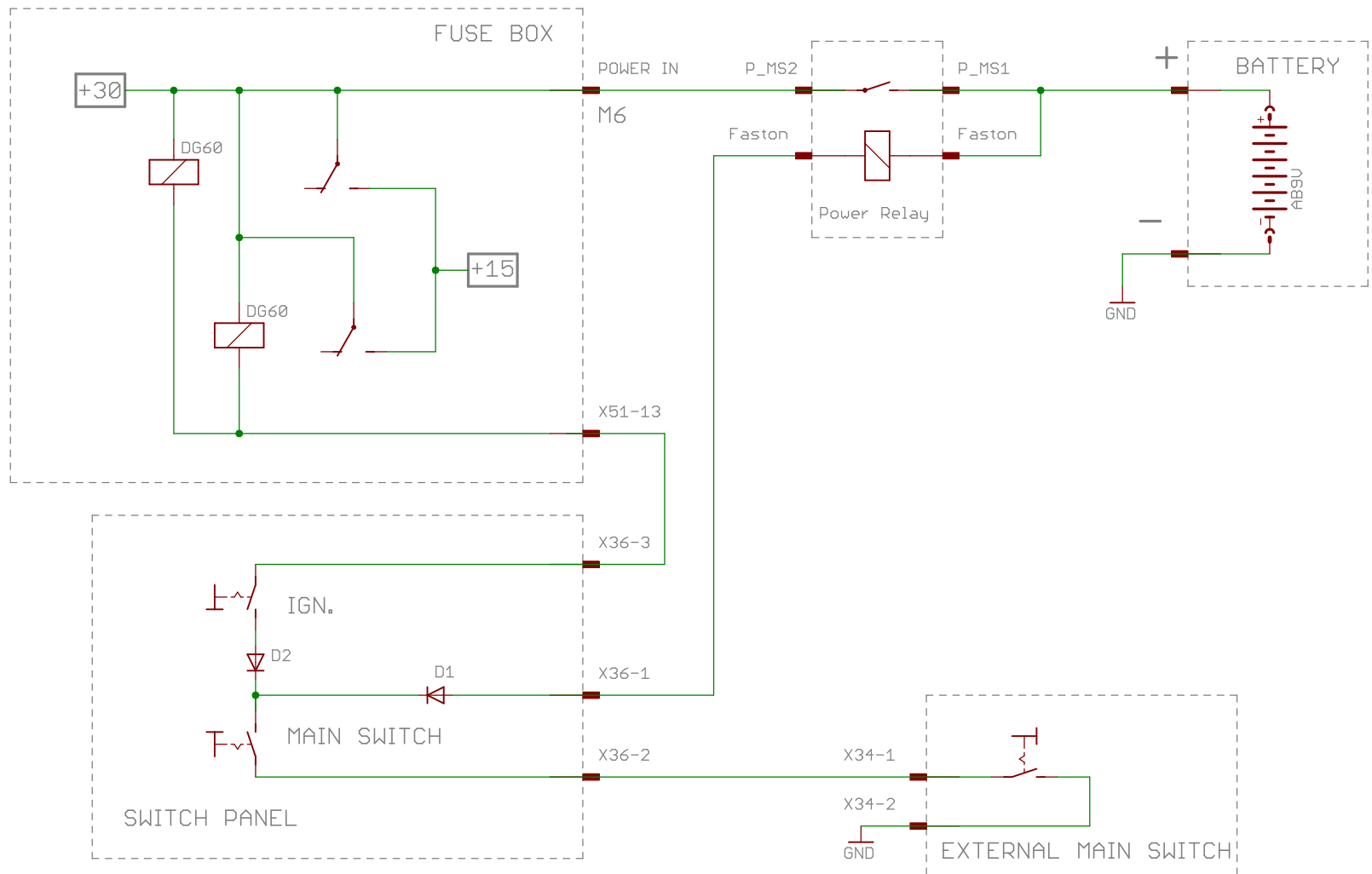

SEAT Sport

by THQtronic

TITLE: MK3_TCR_LEON_schematic_details

Document Number: MainSwitch / Ignition REV:

Date: 25/02/2016 12:04:19

Sheet: 7/26

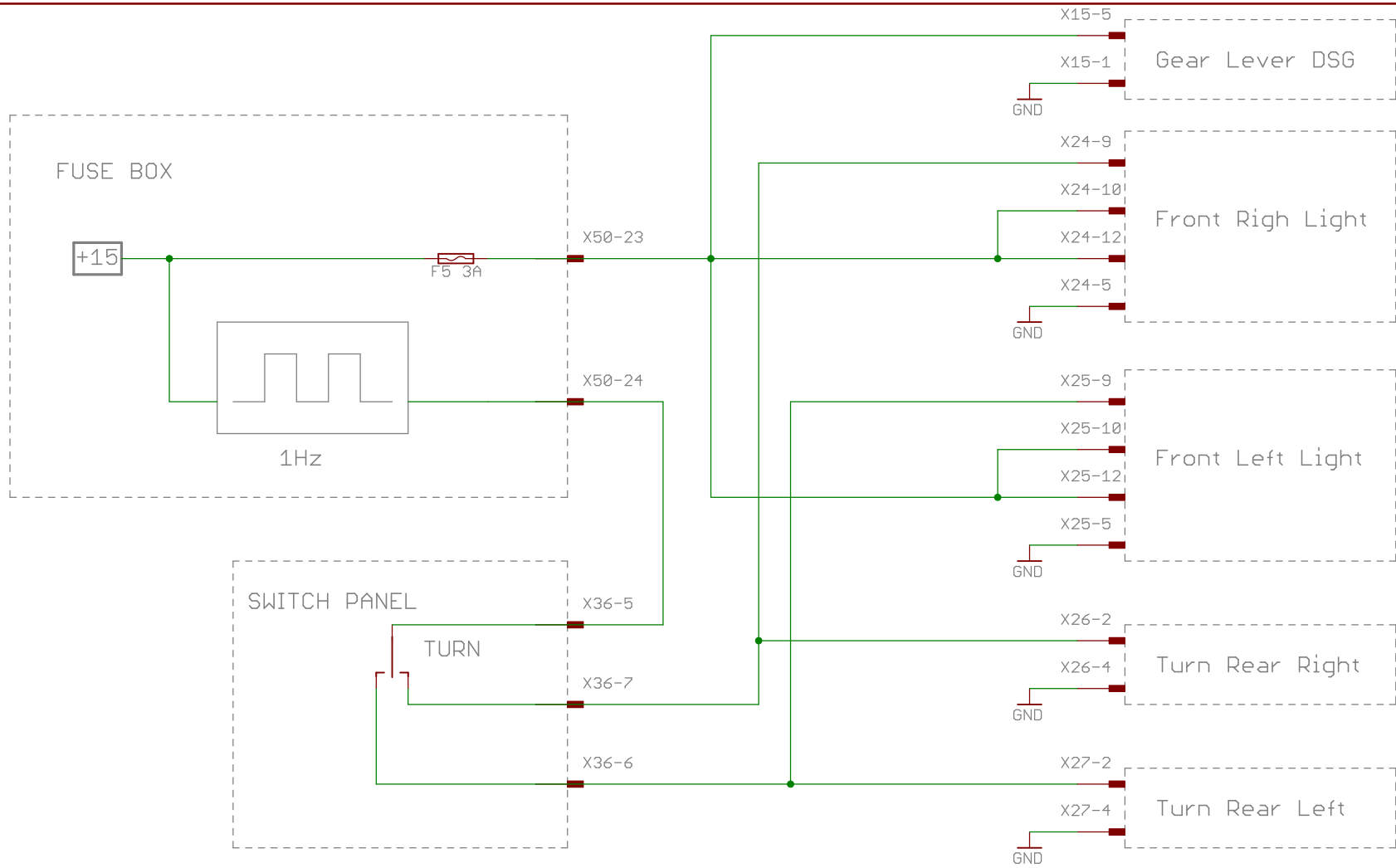

SEAT Sport

by THQtronic

TITLE: MK3_TCR_LEON_schematic_details

Document Number: Turn and Day Light

REV:

Date: 25/02/2016 12:04:19

Sheet: 8/26

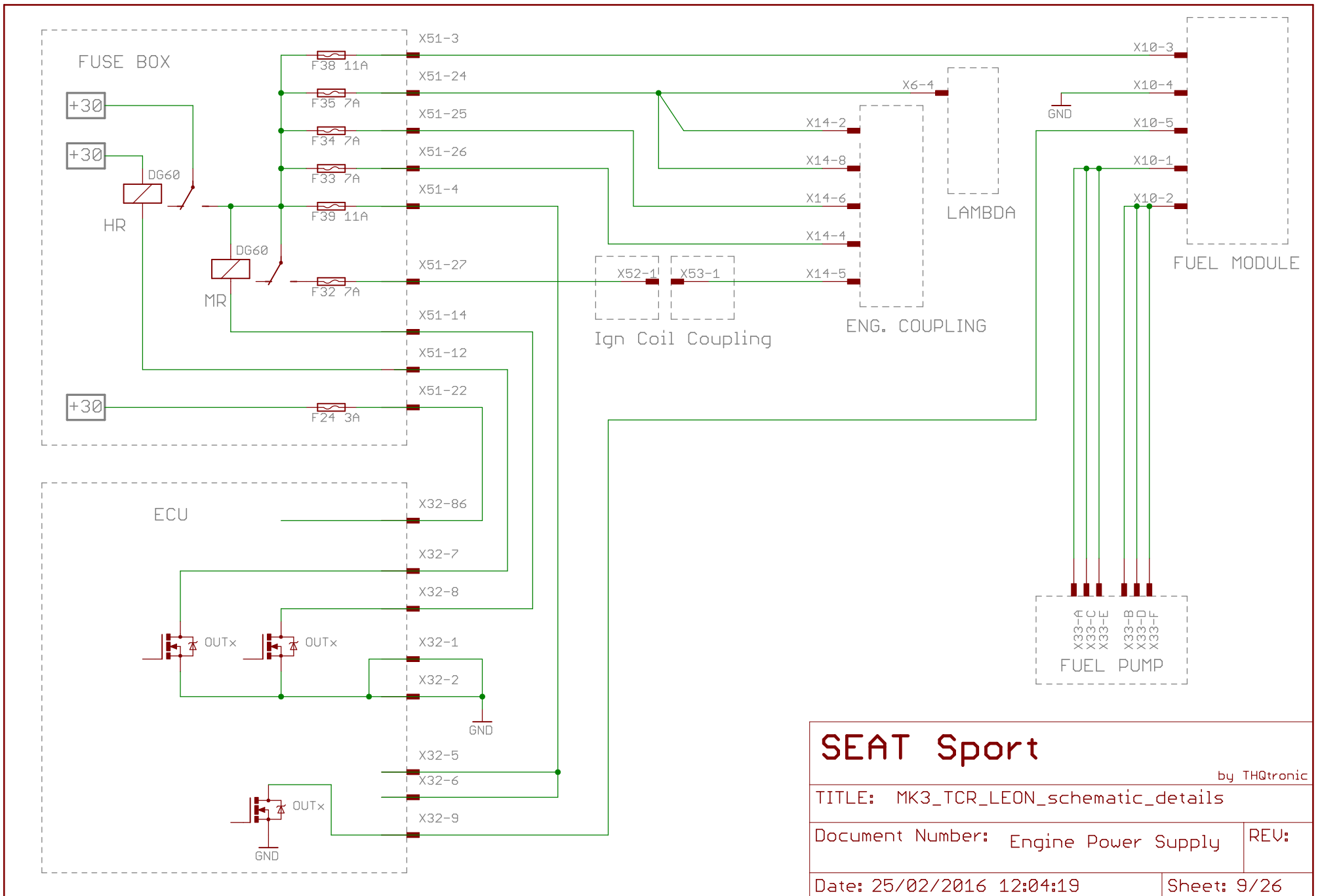

| | | |
|---------------------------------------|-------------|--------------|
| SEAT Sport | | by THQtronic |
| TITLE: MK3_TCR_LEON_schematic_details | | |
| Document Number: Engine Power Supply | REV: | |
| Date: 25/02/2016 12:04:19 | Sheet: 9/26 | |

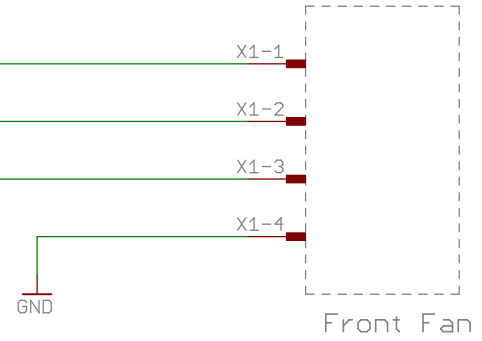
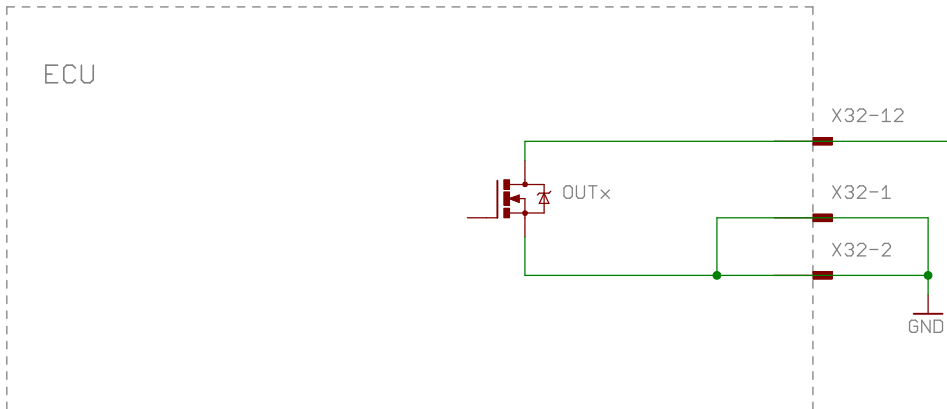
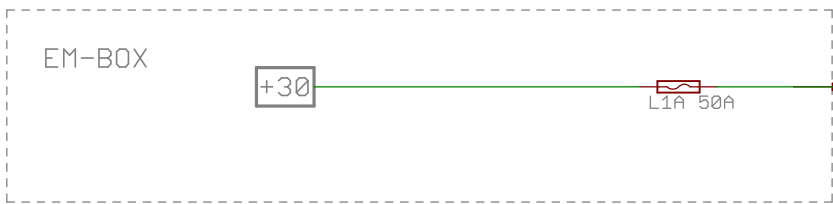

SEAT Sport

by THQtronic

TITLE: MK3_TCR_LEON_schematic_details

Document Number: Front Fan

REV:

Date: 25/02/2016 12:04:19

Sheet: 10/26

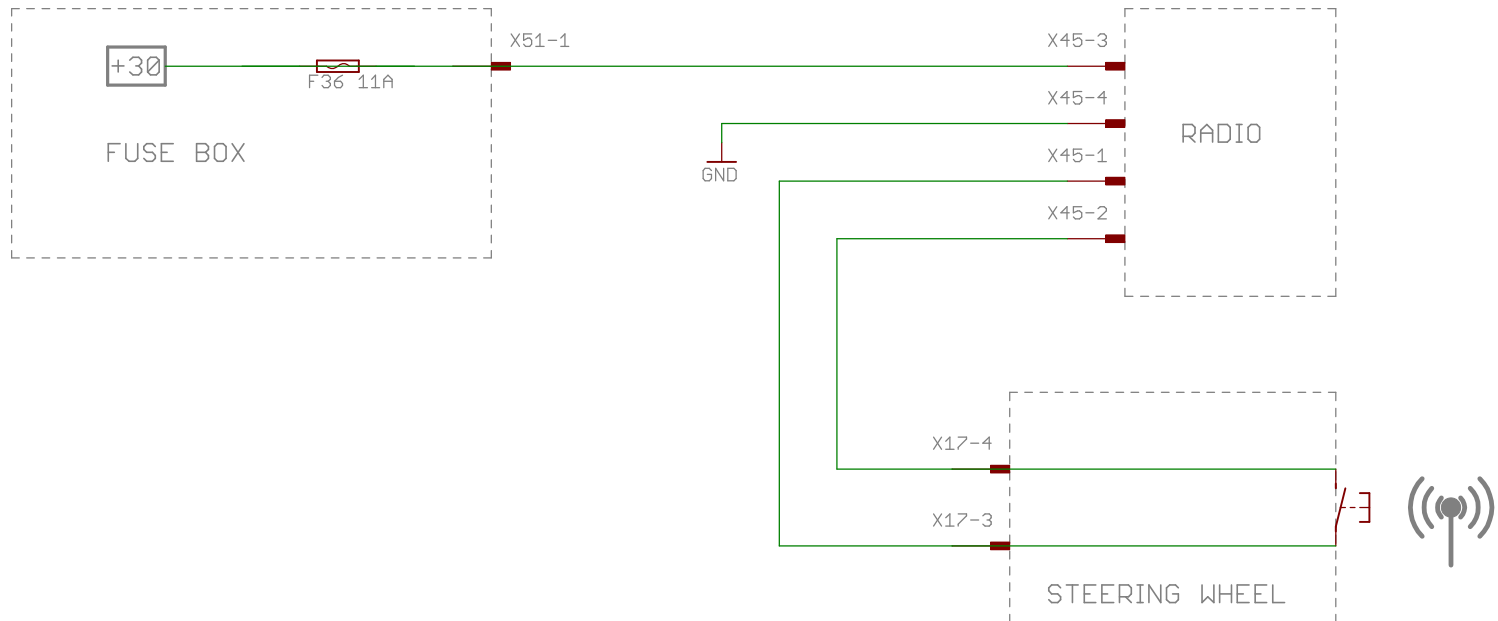

| | | |
|---------------------------------------|--------------|--------------|
| SEAT Sport | | by TH0tronic |
| TITLE: MK3_TCR_LEON_schematic_details | | |
| Document Number: | Radio | REV: |
| Date: 25/02/2016 12:04:19 | Sheet: 11/26 | |

KSK

DOOR WIRING

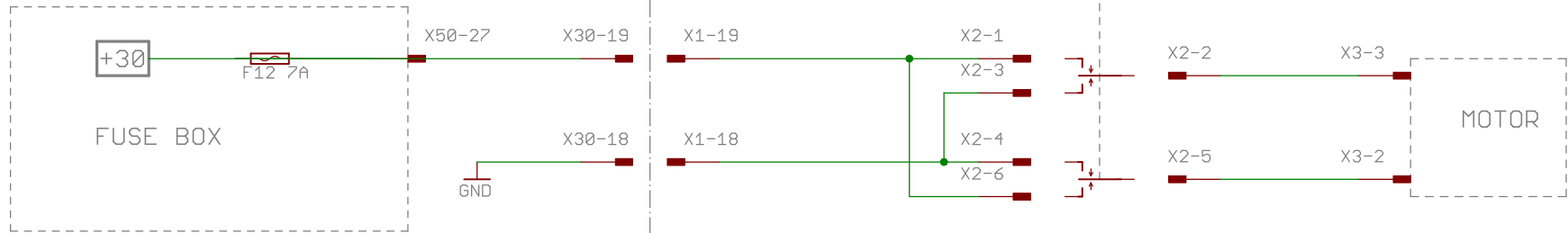

SEAT Sport

by THQtronic

TITLE: MK3_TCR_LEON_schematic_details

Document Number: Window

REV:

Date: 25/02/2016 12:04:19

Sheet: 12/26

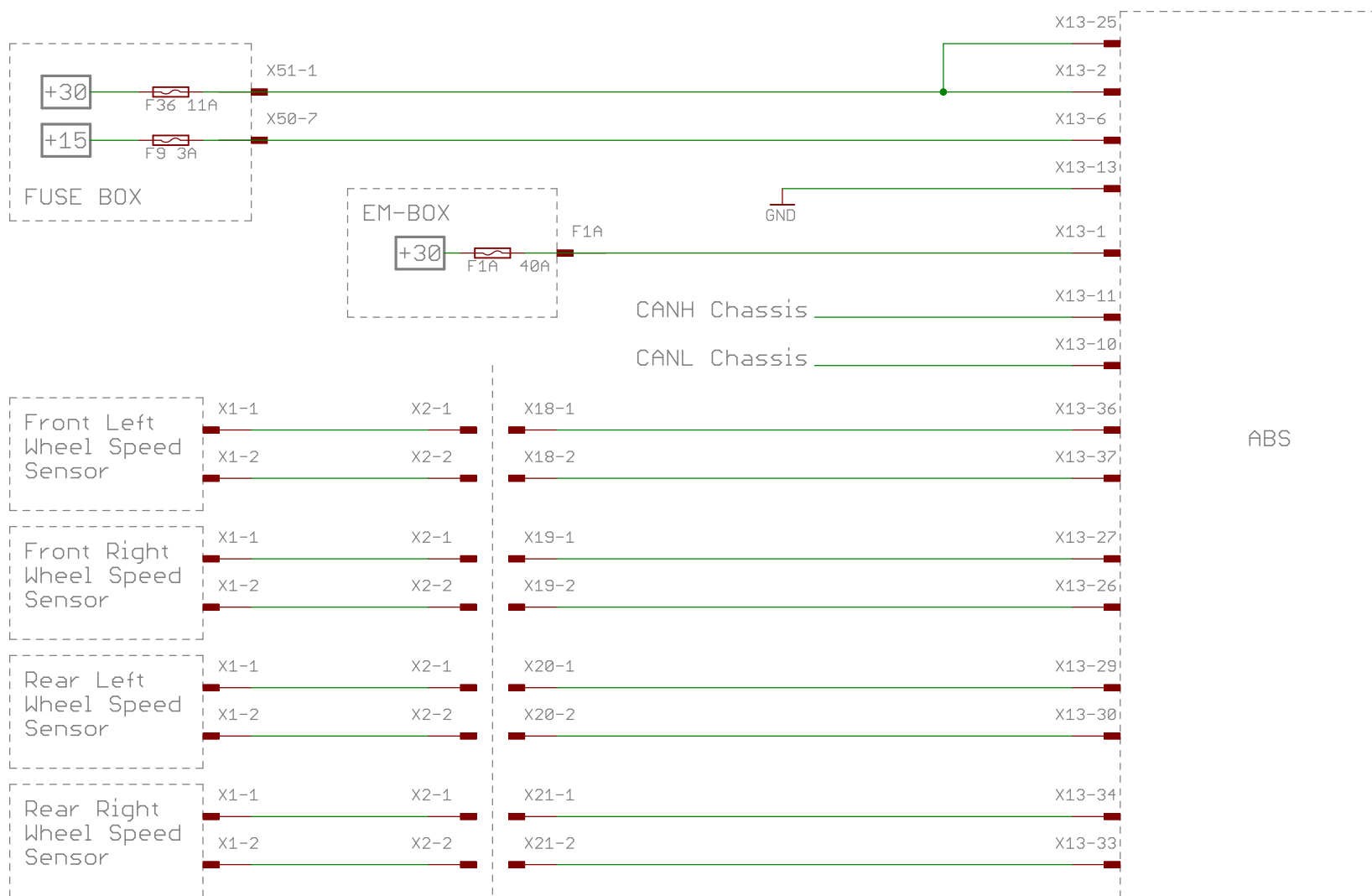

SEAT Sport

by THQtronic

TITLE: MK3_TCR_LEON_schematic_details

Document Number: ABS

REV:

Date: 25/02/2016 12:04:19

Sheet: 13/26

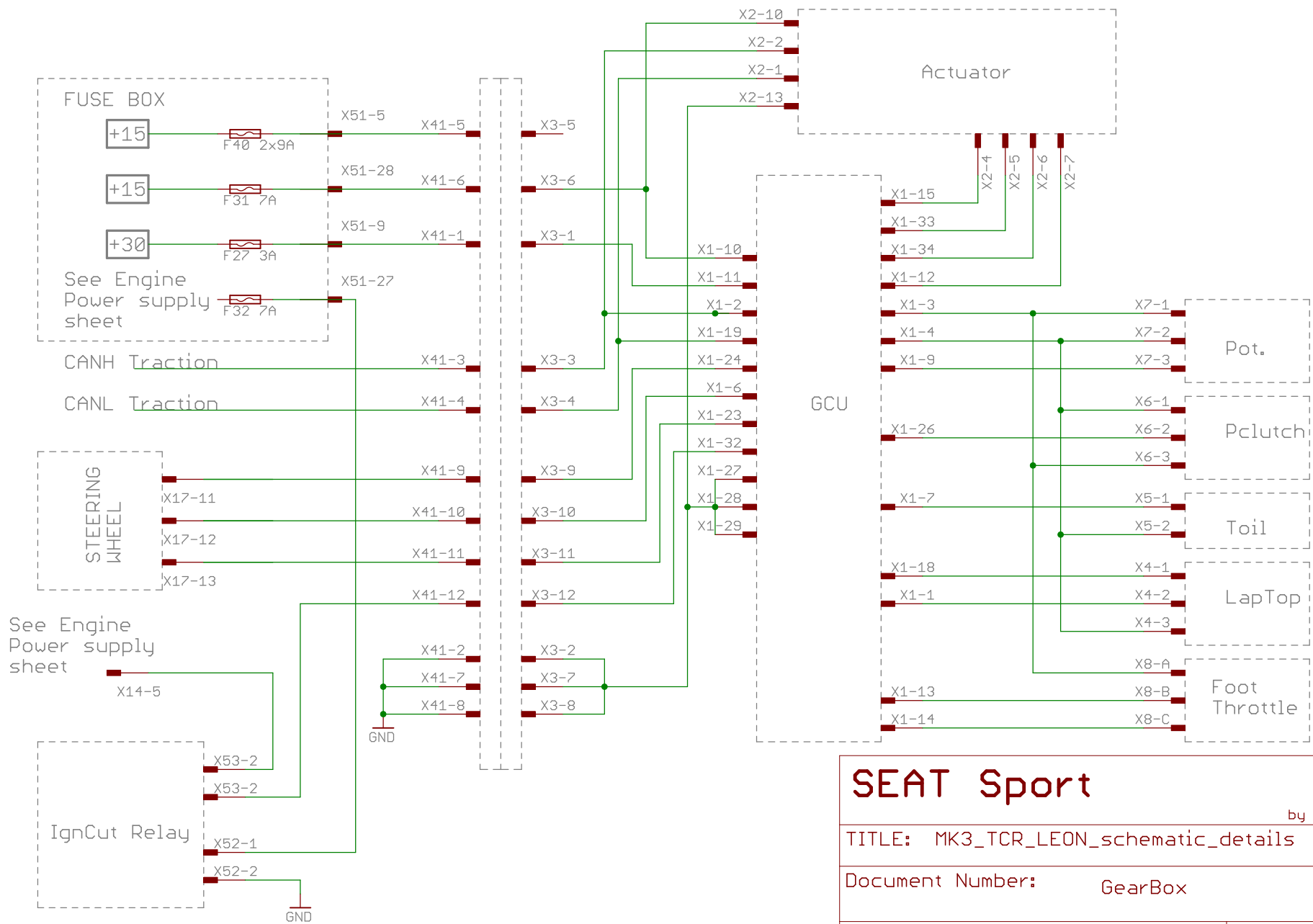

| | | |
|---------------------------------------|--------------|--------------|
| <h1>SEAT Sport</h1> | | by THQtronic |
| TITLE: MK3_TCR_LEON_schematic_details | | |
| Document Number: | GearBox | REV: |
| Date: 25/02/2016 12:04:19 | Sheet: 14/26 | |

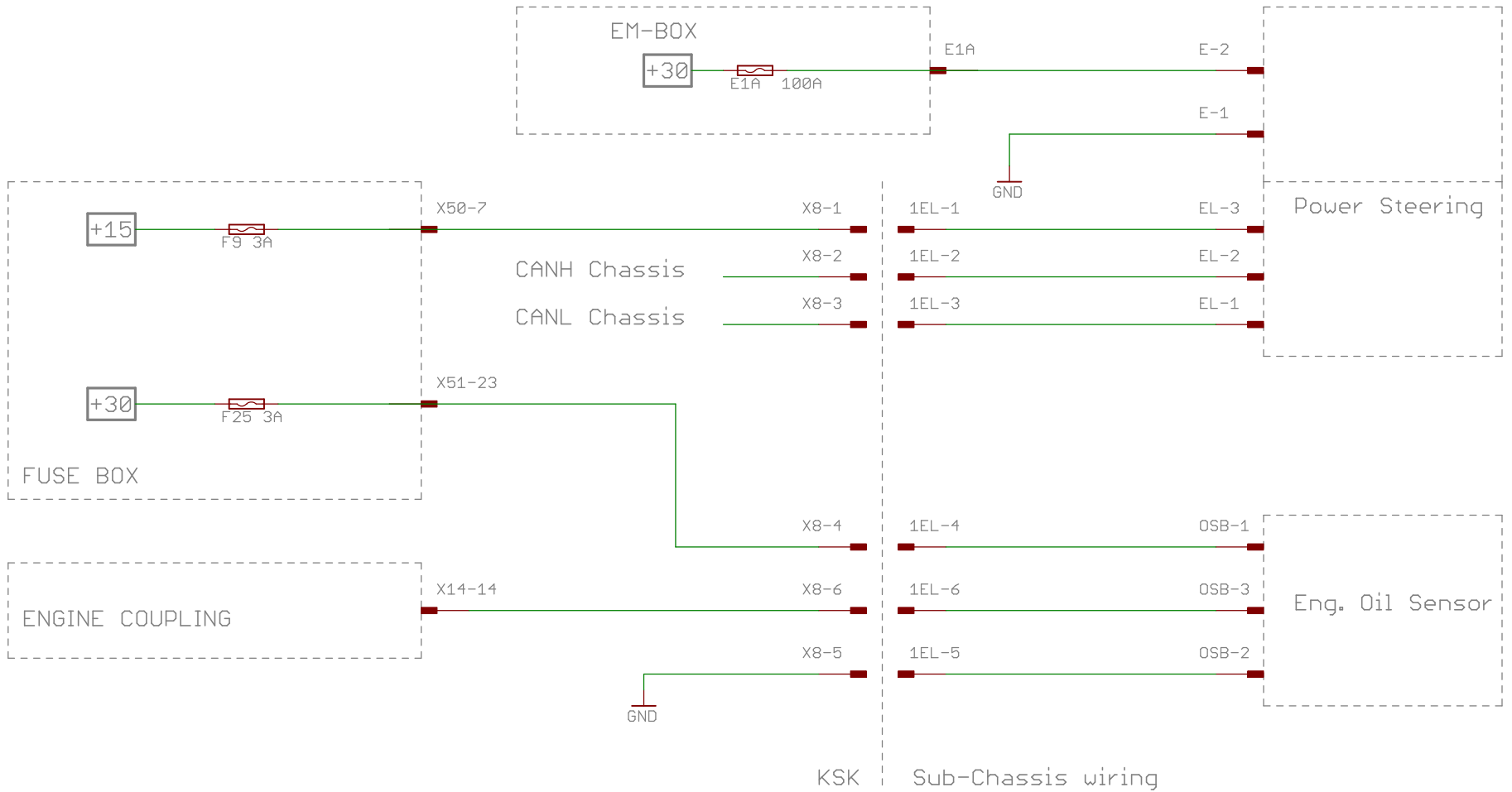

SEAT Sport

by THQtronic

TITLE: MK3_TCR_LEON_schematic_details

Document Number: POWER STEERING

REV:

Date: 25/02/2016 12:04:19

Sheet: 15/26

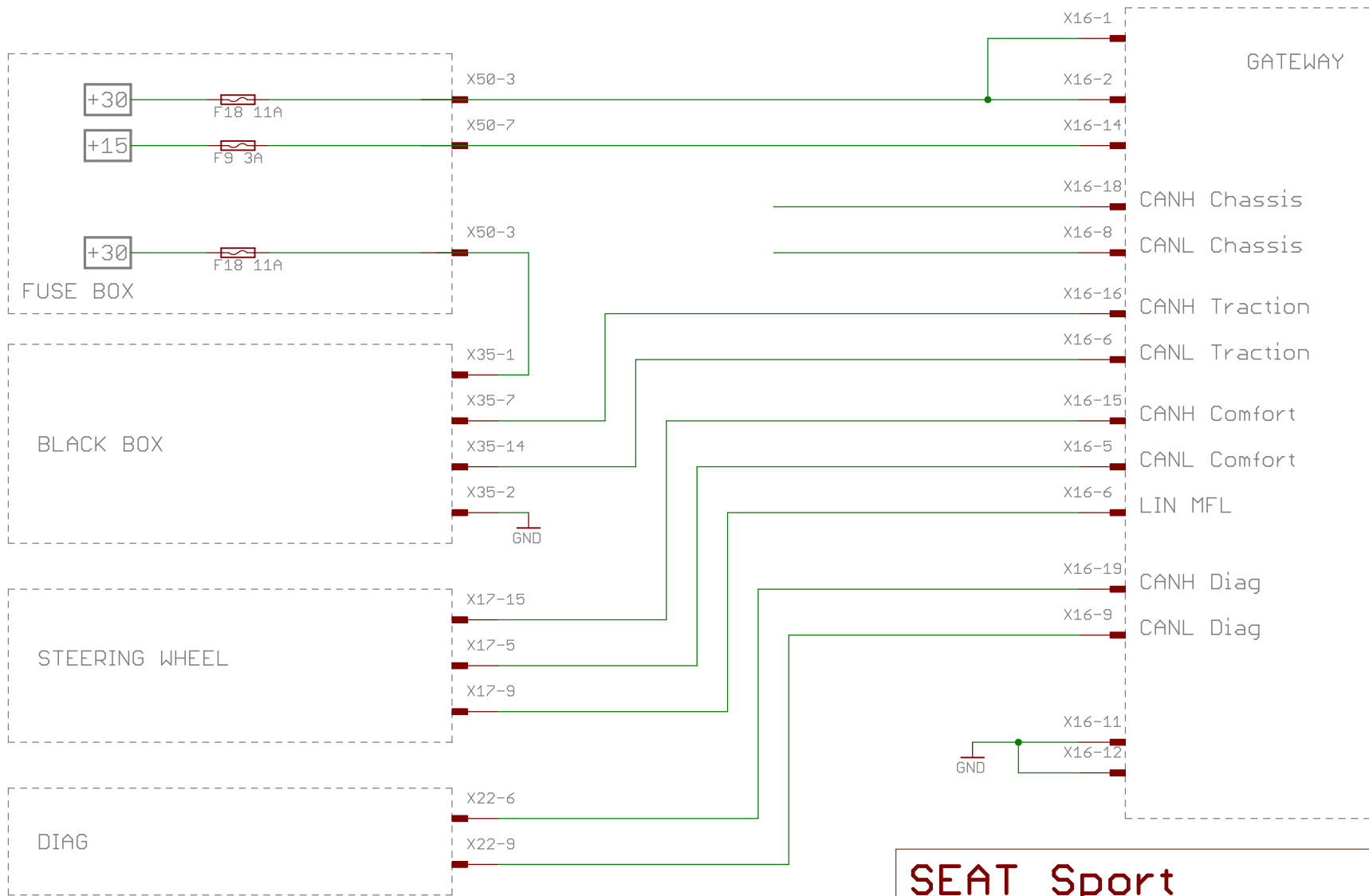

SEAT Sport

by THQtronic

TITLE: MK3_TCR_LEON_schematic_details

Document Number: GATEWAY / BLACKBOX

REV:

Date: 25/02/2016 12:04:19

Sheet: 16/26

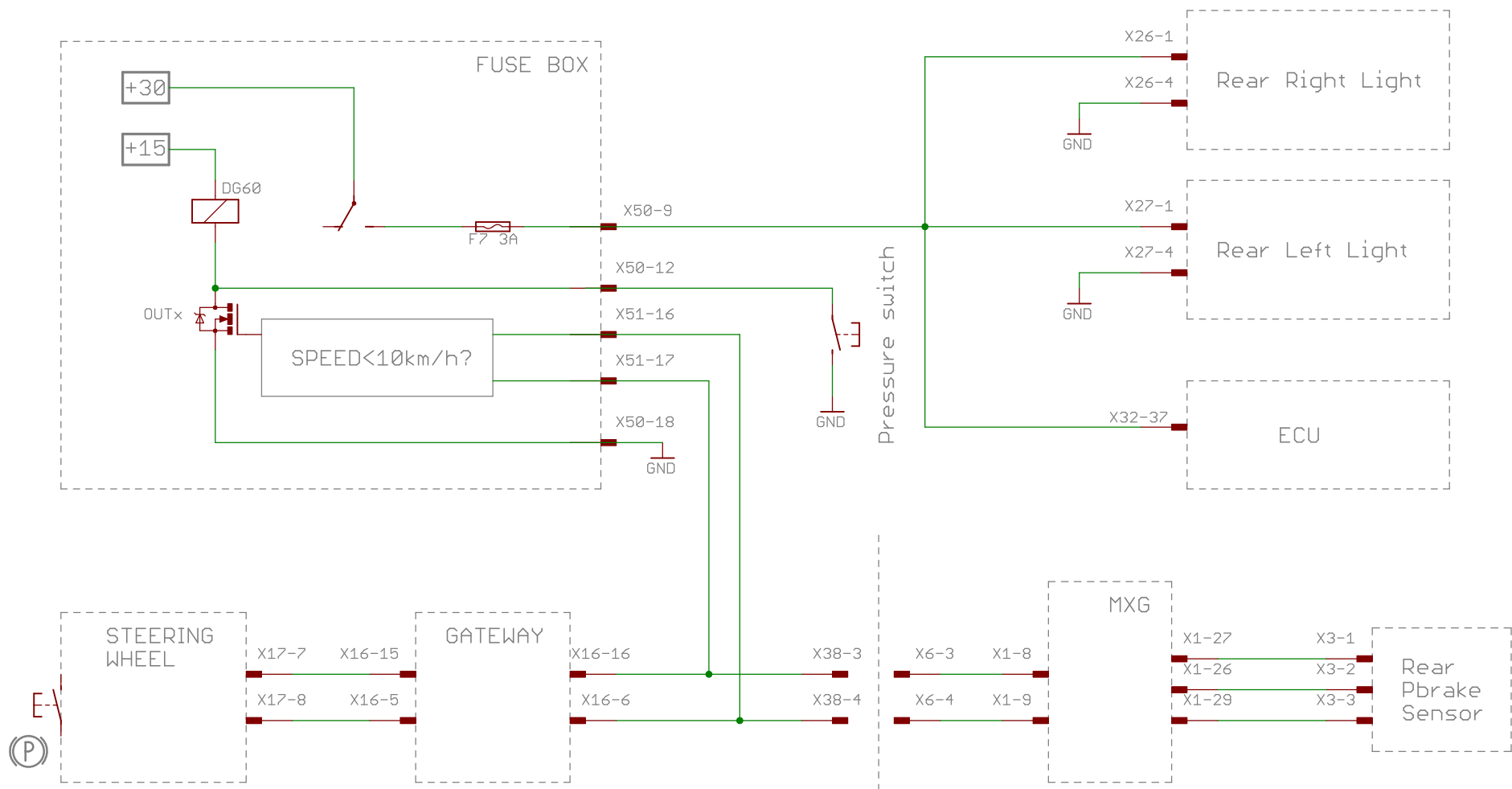

SEAT Sport

by THQtronic

TITLE: MK3_TCR_LEON_schematic_details

Document Number: Brake Light REV:

Date: 25/02/2016 12:04:19

Sheet: 17/26

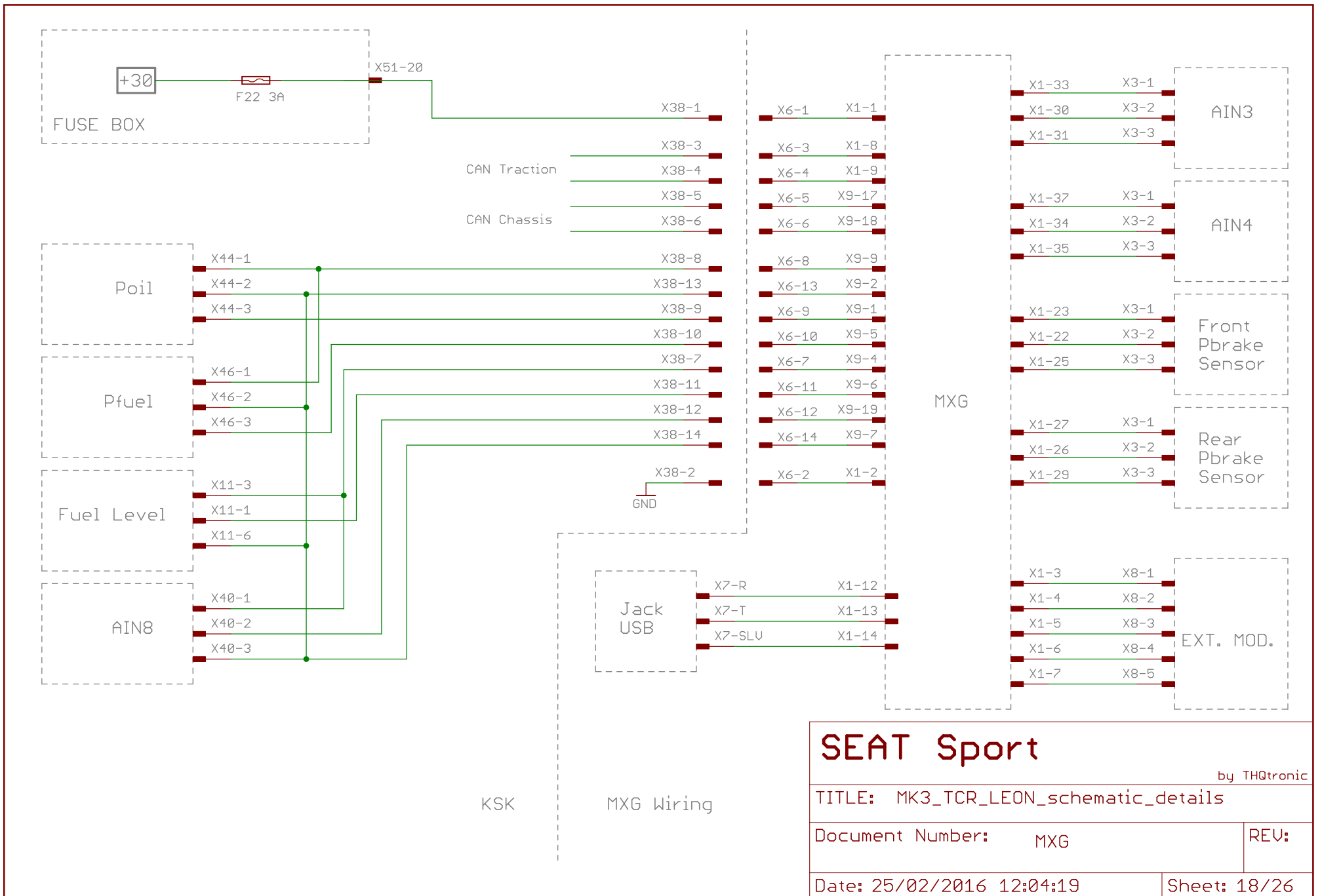

| | | |
|---------------------------------------|--------------|--------------|
| <h1>SEAT Sport</h1> | | by THQtronic |
| TITLE: MK3_TCR_LEON_schematic_details | | |
| Document Number: | MXG | REV: |
| Date: 25/02/2016 12:04:19 | Sheet: 18/26 | |

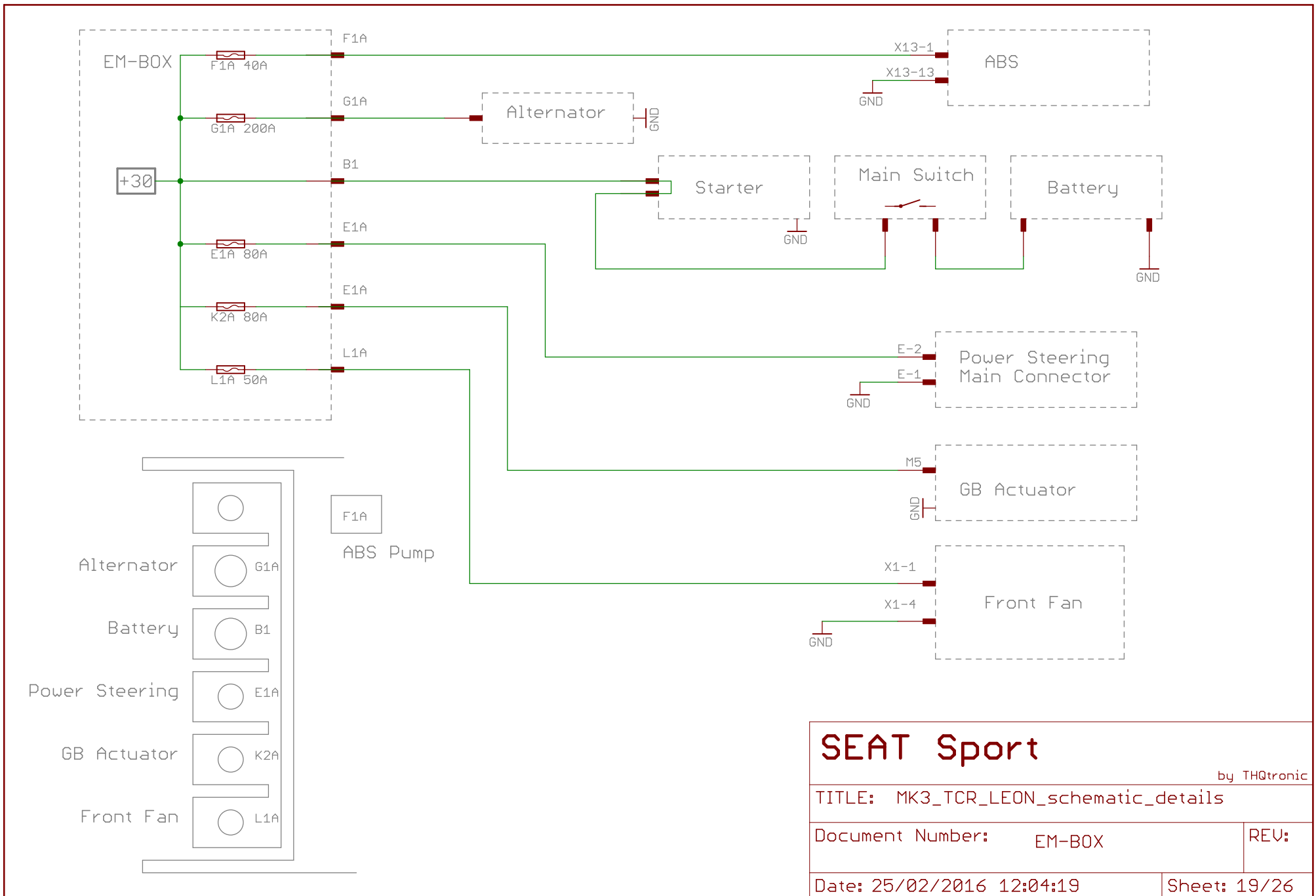

| | | |
|---------------------------------------|--------------|--------------|
| SEAT Sport | | by THQtronic |
| TITLE: MK3_TCR_LEON_schematic_details | | |
| Document Number: | EM-BOX | REV: |
| Date: 25/02/2016 12:04:19 | Sheet: 19/26 | |

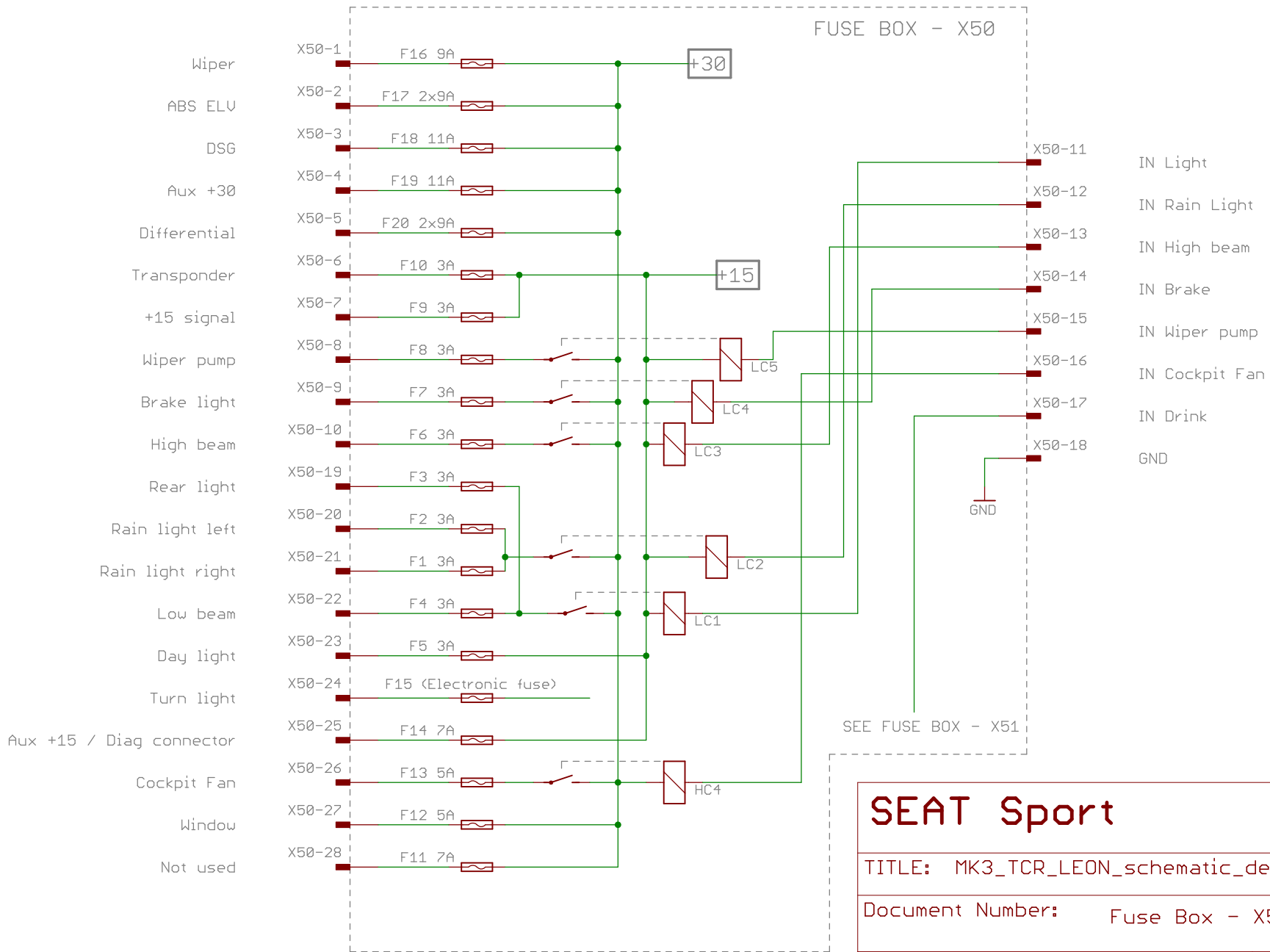

SEAT Sport

by THQtronic

TITLE: MK3_TCR_LEON_schematic_details

Document Number: Fuse Box - X50

REV:

Date: 25/02/2016 12:04:19

Sheet: 20/26

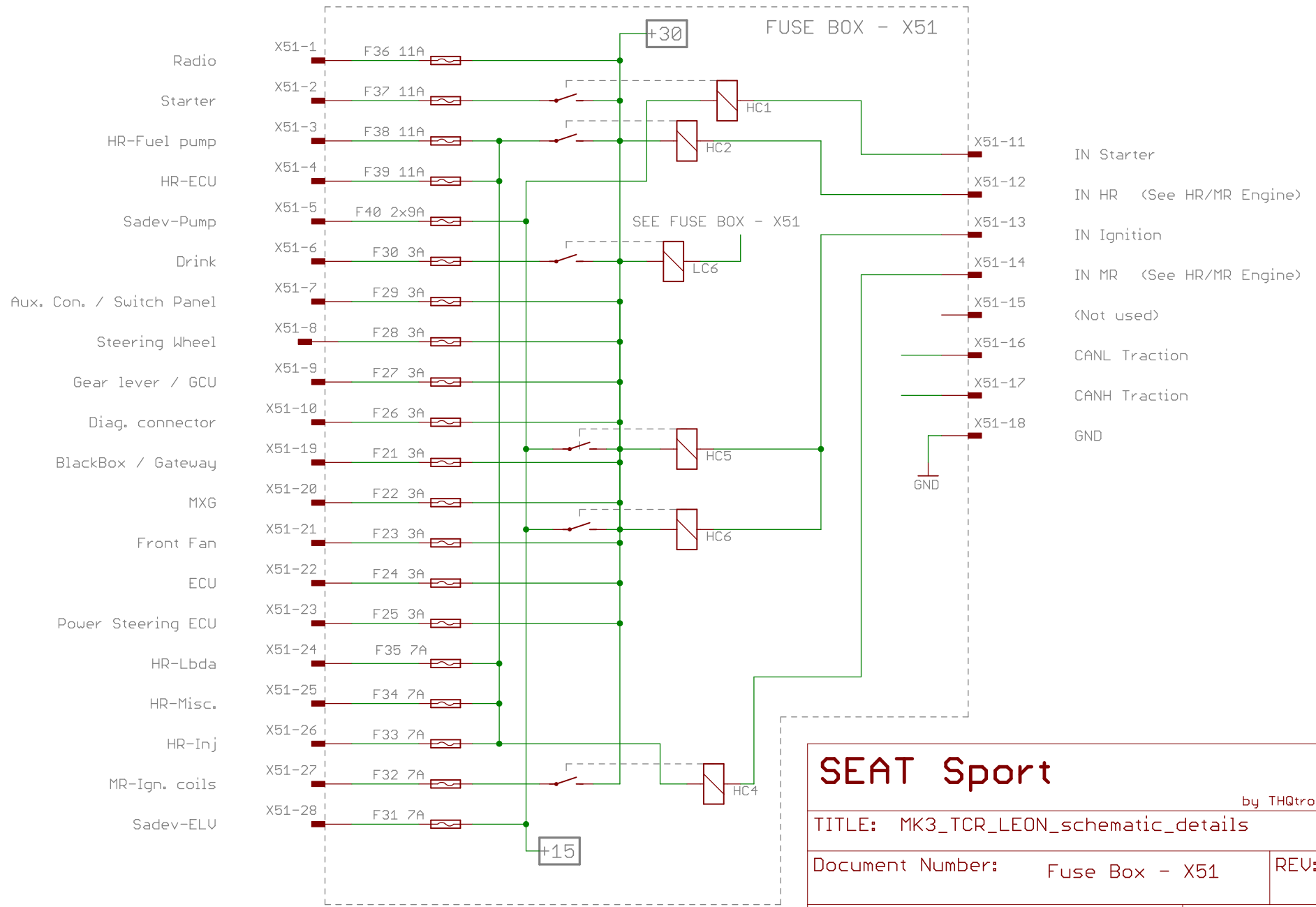

SEAT Sport

by THQtronic

TITLE: MK3_TCR_LEON_schematic_details

Document Number: Fuse Box - X51

REV:

Date: 25/02/2016 12:04:19

Sheet: 21/26

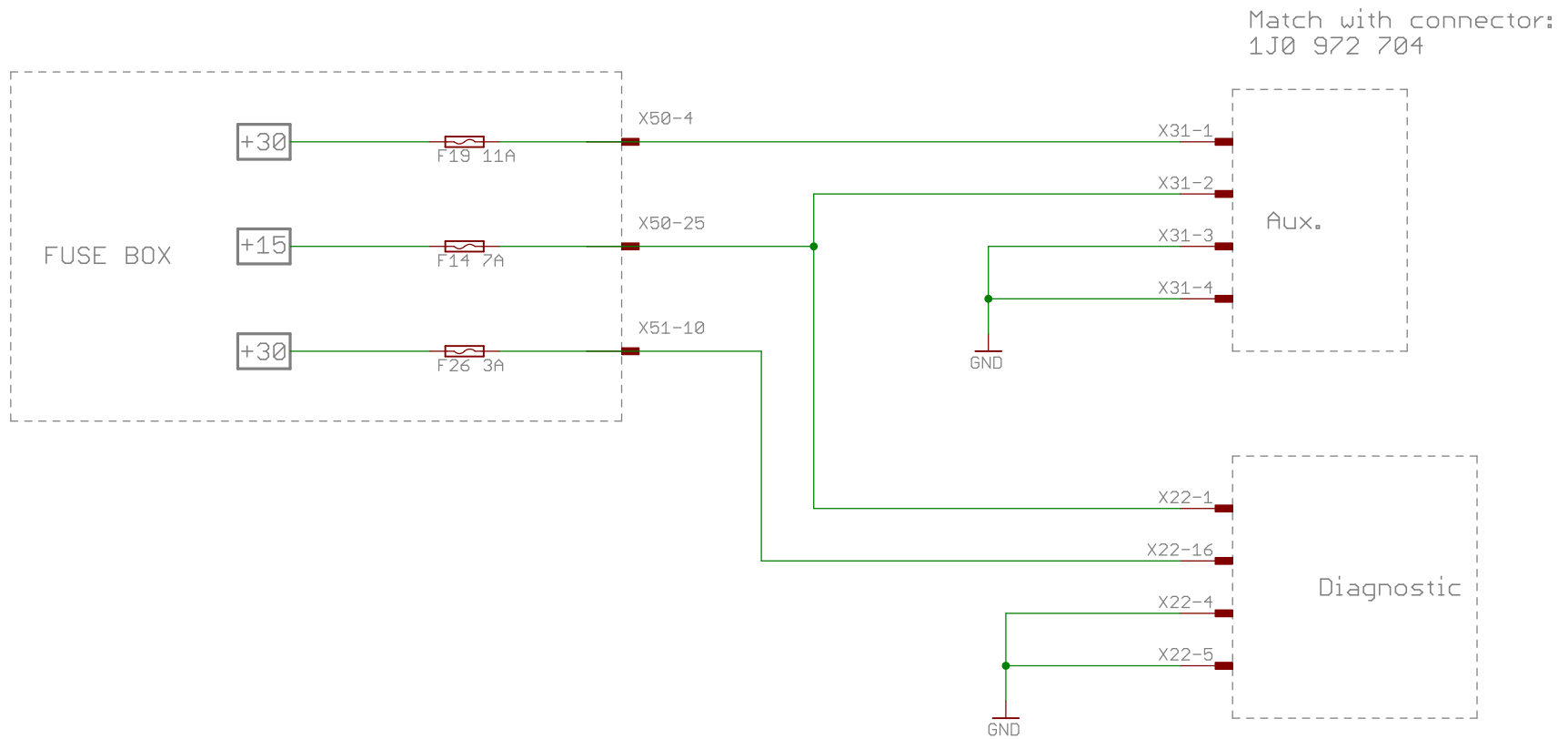

SEAT Sport

by THQtronic

TITLE: MK3_TCR_LEON_schematic_details

Document Number: Auxiliar / Diagnostic

REV:

Date: 25/02/2016 12:04:19

Sheet: 22/26

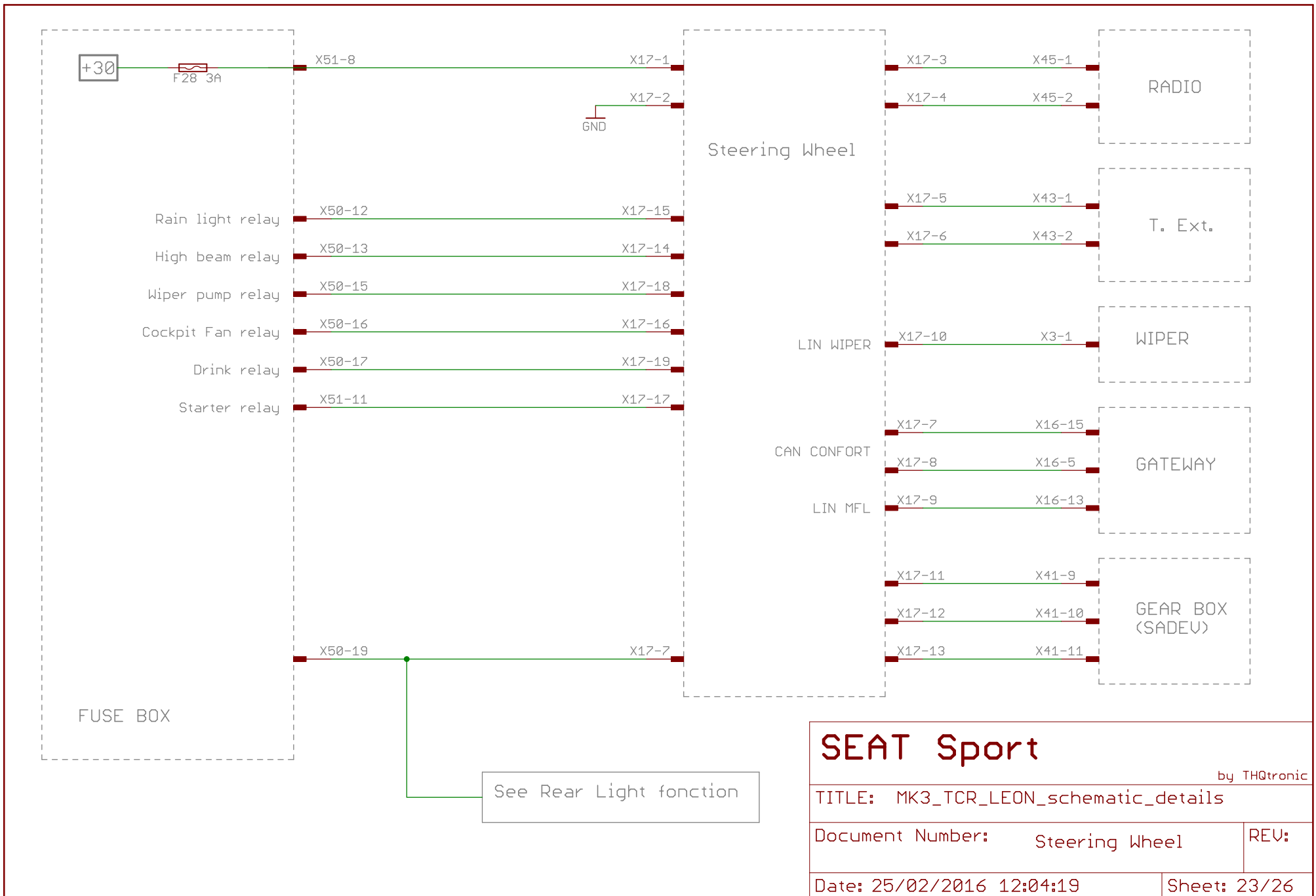

| | | |
|---------------------------------------|----------------|--------------|
| <h1>SEAT Sport</h1> | | by THQtronic |
| TITLE: MK3_TCR_LEON_schematic_details | | |
| Document Number: | Steering Wheel | REV: |
| Date: 25/02/2016 12:04:19 | Sheet: 23/26 | |

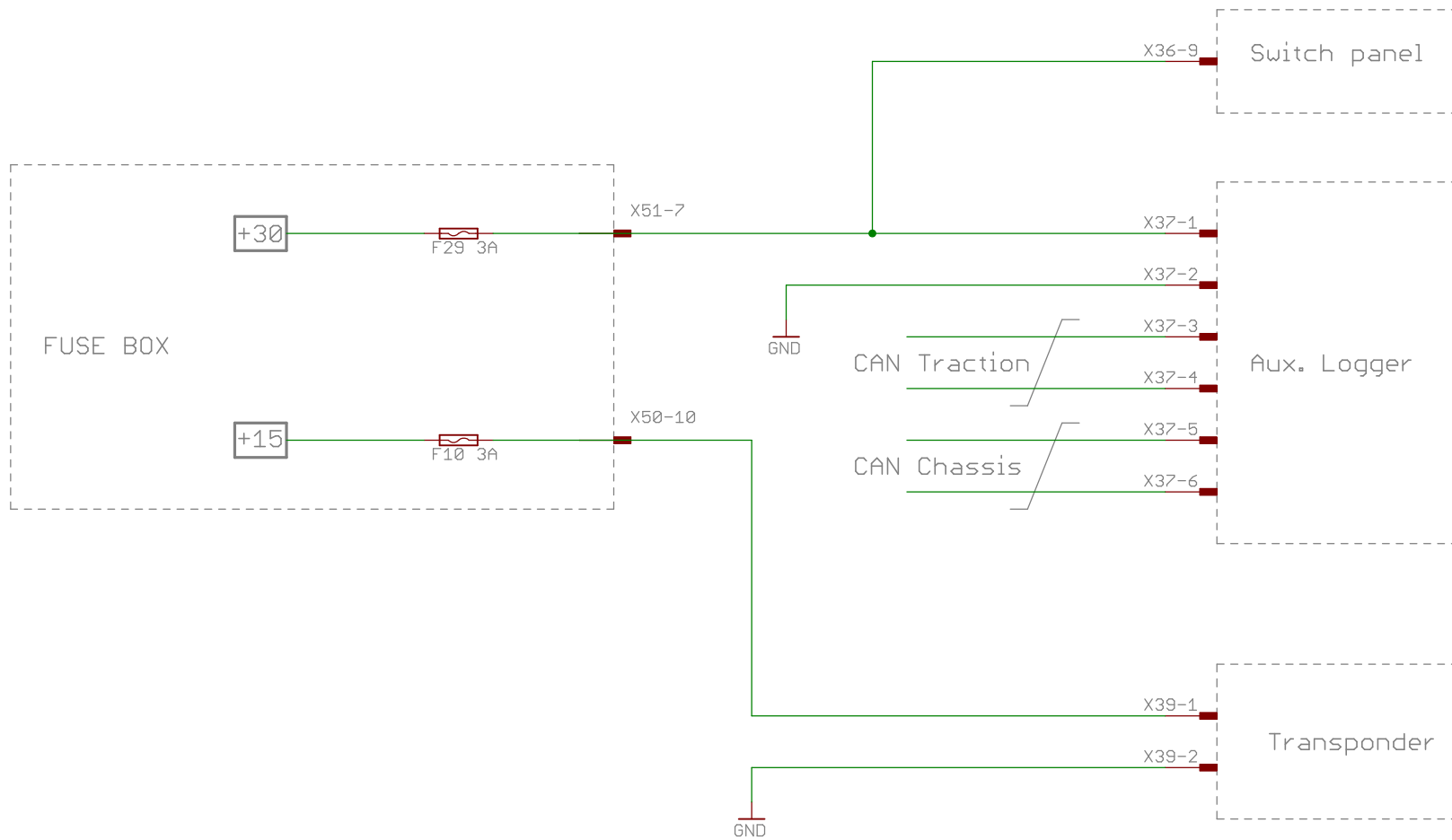

SEAT Sport

by THQtronic

TITLE: MK3_TCR_LEON_schematic_details

Document Number: Aux. Logger / Transponder REU:

Date: 25/02/2016 12:04:19

Sheet: 24/26

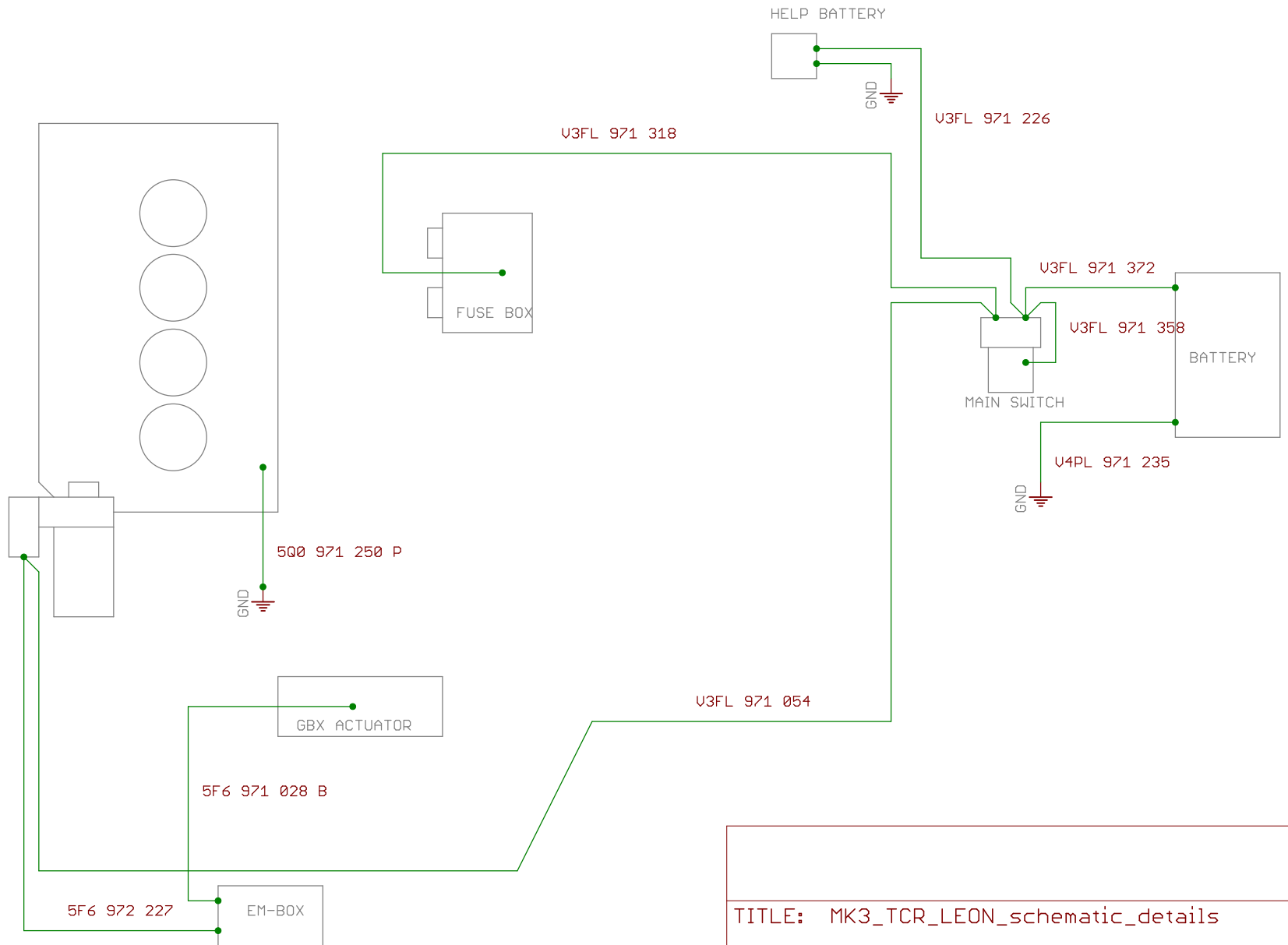

TITLE: MK3_TCR_LEON_schematic_details

Document Number: POWER CABLES LAYOUT REV:

Date: 25/02/2016 12:04:19

Sheet: 25/26

| | | | | | |
|-----|-------------------------|---------------|-----|-------------------------|---------------|
| X1 | Front Fan | 1K0 906 234 | X33 | Fuel pump | AS6 10-98 SN |
| X2 | Wiper pump | 1J0 973 722 | X34 | External main switch | Faston 6.35 |
| X3 | Wiper | 8K0 973 724 | X35 | Black box | 8E0 972 416 |
| X4 | Starter | 1K0 973 751 | X36 | Switch panel | 1-794617-2 |
| X5 | Alternator | 4H0 973 714 | X37 | Aux. data logger | 1J0 972 723 |
| X6 | Lambda | 8K0 973 705 G | X38 | MXG coupling | 1-794615-6 |
| X7 | EM-Box | | X39 | Transponder | 357 972 752 |
| X8 | Power steering coupling | 4H0 973 713 | X40 | AIN8 | 1J0 972 703 |
| X9 | Differential unit | 8D0 973 734 | X41 | Sadev coupling | 3C0 973 737 |
| X10 | Fuel pump module | 6N0 973 755 | X42 | Main switch coil | 1J0 972 711 |
| X11 | Fuel level | 4H0 973 713 G | X43 | Ext. temperature sensor | 8K0 973 702 |
| X12 | DSG | 1J0 927 320 | X44 | P. Oil | 4D0 971 993 A |
| X13 | ABS | 3C0 973 038 A | X45 | Radio | Super Seal |
| X14 | Engine coupling | 5Q0 973 737 | X46 | P. Fuel | 4D0 971 993 A |
| X15 | DSG gear lever | 1k0 972 776 | X47 | Cockpit fan | 1J0 972 752 |
| X16 | Gateway | 8E0 972 420 | X48 | Temp. sensor | 8K0 973 702 |
| X17 | Steering wheel | 2-794615-4 | X50 | Fusebox 1 | 064318-1011 |
| X18 | FL wheelspeed sensor | 1J0 972 702 | X51 | Fusebox 2 | 064318-3019 |
| X19 | FR wheelspeed sensor | 1J0 972 702 | X52 | IgnCoil out | 1J0 972 702 |
| X20 | RL wheelspeed sensor | 1J0 972 702 | X53 | IgnCoil in | 1J0 972 712 |
| X21 | RR wheelspeed sensor | 1J0 972 702 | X54 | Fuel pump out | 1J0 972 752 |
| X22 | Diagnostic | 3A0 972 695 A | X55 | Fuel pump in | 1J0 972 762 |
| X23 | Foot throttle | 8K0 973 706 | | | |
| X24 | Front Right light | 3C0 973 737 | | | |
| X25 | Front Left light | 3C0 973 737 | | | |
| X26 | Rear right light | 4B0 973 732 | | | |
| X27 | Rear left light | 4B0 973 732 | | | |
| X28 | Rear gate | 1J0 972 704 | | | |
| X29 | Drink | 1J0 973 722 | | | |
| X30 | Left door | 8K0 972 701 | | | |
| X31 | Auxiliar | 4D0 972 704 | | | |
| X32 | ECU | 7P6 906 971 A | | | |

SEAT Sport

by THQtronic

TITLE: MK3_TCR_LEON_schematic_details

Document Number: Connector list

REV:

Date: 25/02/2016 12:04:19

Sheet: 26/26